

CLEAR FLOOR SPACE NON-RESIDENTIAL TOILET ROOMS FOR INDIVIDUAL USE

<p>Clark County Dept. of Develop. Services 4701 W Russell Rd Las Vegas, NV 89118 (702) 455-3000</p>	<p>Boulder City Building Department 401 California Avenue Boulder City, NV 89005 (702) 293-9282</p>	<p>Henderson Bldg & Fire Safety Dept. 240 Water Street Henderson, NV 89015 (702) 267-3650</p>	<p>Las Vegas Building & Safety Dept. 731 S. 4th Street Las Vegas, NV 89101 (702) 229-6916</p>
---	---	---	---

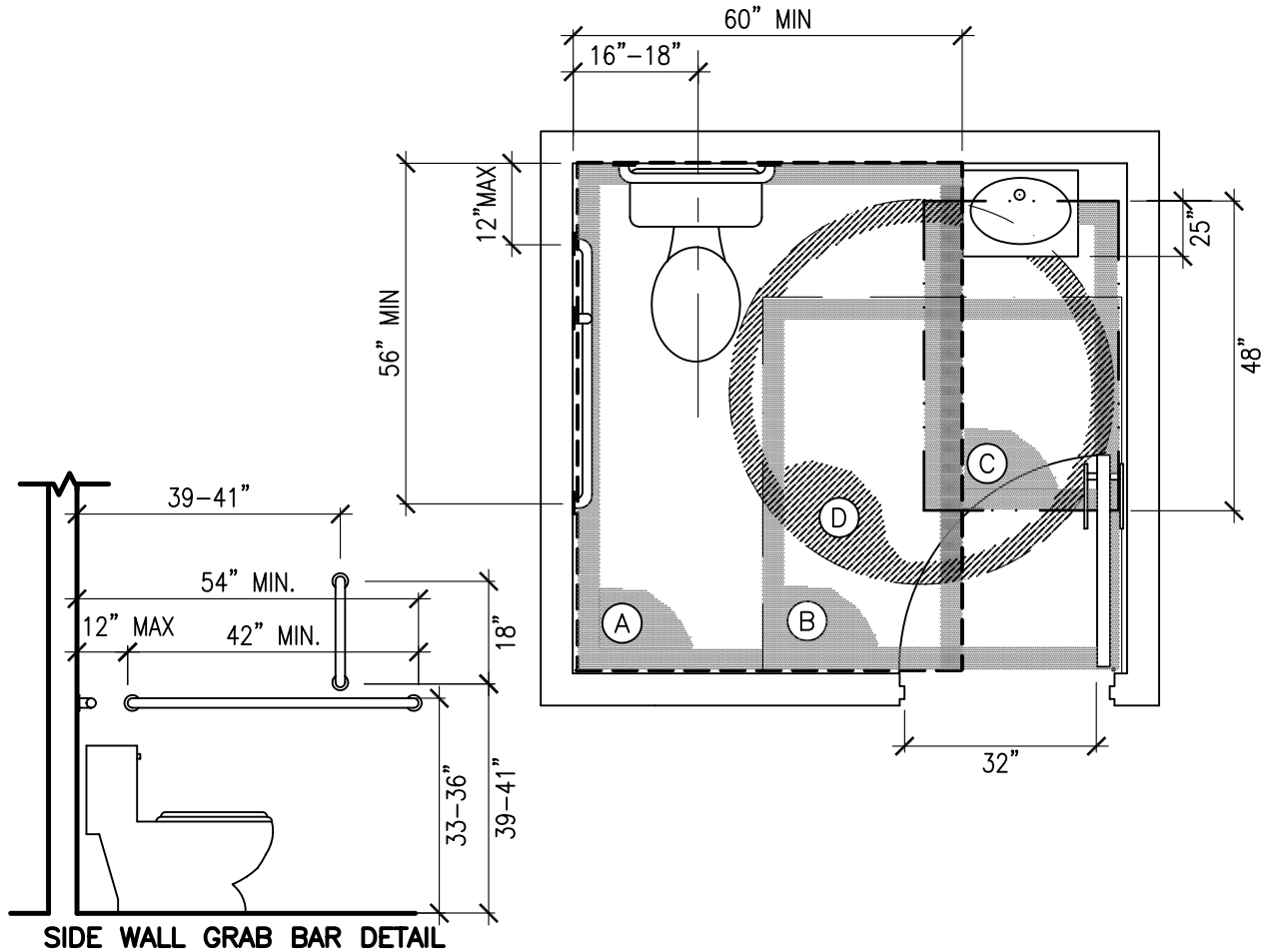

- (A) CLEAR FLOOR SPACE AT WATERCLOSET
- (B) CLEAR FLOOR SPACE AT DOOR PER ICC/ANSI CHAPTER 4
- (C) CLEAR FLOOR SPACE AT LAVATORY 30"X 48" FOR FORWARD APPROACH AND MAY EXTEND A MAXIMUM OF 25" UNDER THE LAVATORY.
- (D) WHEELCHAIR TURNING SPACE; 60" DIAMETER CIRCLE OR T-SHAPE PER ANSI 4.2.3. CLEAR FLOOR SPACES MAY OVERLAP EACH OTHER.

DOORS SHALL NOT SWING INTO THE CLEAR FLOOR SPACE REQUIRED FOR ANY FIXTURE UNLESS THE TOILET ROOM IS FOR INDIVIDUAL USE ONLY OR A CLEAR FLOOR SPACE 30"X48" IS PROVIDED BEYOND THE ARC OF THE DOOR SWING IN THE TOILET ROOM.

<p>Mesquite Building Department 10 East Mesquite Blvd. Mesquite, NV 89027 (702) 346-2835</p>	<p>North Las Vegas Building Department 2240 Civic Center Drive N. Las Vegas, NV 89030 (702) 633-1577</p>	<p>Pahrump Regional Planning District 1210 E. Basin Avenue, Suite #1 Pahrump, NV 89060 (775) 751-3373</p>	
--	--	---	--